



**Probing Solutions.
Made in Germany.**

EN



BumbleBee[®] Series

High Voltage Differential Probes
up to 500 MHz, up to ± 2000 V

Datasheet



About BumbleBee® Series

The PMK BumbleBee® high voltage differential probe series offers industry leading performance up to 500MHz bandwidth for today's power device design challenges, especially those using wide bandgap devices, such as SiC and GaN. The $\pm 2000\text{V}$, $\pm 1000\text{V}$, $\pm 400\text{V}$ and $\pm 200\text{V}$ differential and common-mode input voltage ranges makes BumbleBee® probes an ideal choice for designing and evaluating power circuits, such as switching power supplies, motor drives, inverter, IGBT circuits and frequency converters in the different voltage classes. BumbleBee® series probes have four adjustable input attenuation ranges allowing the user to select the voltage range needed to achieve the lowest noise and best possible resolution. The probe is compatible with any oscilloscope with a 50Ω input impedance and has a user adjustable DC output offset correction range of $\pm 4\text{V}$ (output referred).

All BumbleBee® series probes can be controlled from the controls located on the probe head or via remote control. The „PMK Probe Control“ software provides the ability for the user to control the probe remotely via a computer, and provides the user with a graphical user interface. The software is free of charge, and included with PMK's 2ch and 4ch power supplies PS-02 and PS-03, which are required to power the probe. The PS-02 and PS-03 power supplies all have a USB interface and are available with optional LAN interface. The 1 channel battery pack power supply AP-01 provides >8h of portable and isolated operation, which allows the user the flexibility of where the probe can be used. The AP-01 supplies power only to the probe with no software remote control.

ISO17025 calibration upon delivery or as re-calibration is available.

Specifications

Electrical Specifications ¹				
Article number	$\pm 2000\text{ V}$ 880-102-501 880-106-501 880-107-501	$\pm 1000\text{ V}$ 880-132-501 880-137-501	$\pm 400\text{ V}$ 880-122-501 880-127-501	$\pm 200\text{ V}$ 880-112-501 880-117-501
Attenuation* ($< \pm 1\%$ guaranteed)	500:1, 250:1, 100:1, 50:1	250:1, 125:1, 50:1, 25:1	100:1, 50:1, 20:1, 10:1	50:1, 25:1, 10:1, 5:1
Bandwidth* (-3 dB) Small Signal (guaranteed)	250:1, 500:1: 400 MHz 50:1, 100:1: 400 MHz	250:1, 125:1: 500 MHz 50:1, 25:1: 400 MHz	100:1, 50:1: 500 MHz 20:1, 10:1: 400 MHz	50:1, 25:1: 500 MHz 10:1, 5:1: 400 MHz
Rise time (10 % - 90 %) Small Signal	250:1, 500:1: 0.9 ns 50:1, 100:1: 1.0 ns	250:1, 125:1: 0.8 ns 50:1, 25:1: 0.95 ns	100:1, 50:1: 0.8 ns 20:1, 10:1: 0.95 ns	50:1, 25:1: 0.8 ns 10:1, 5:1: 0.95 ns
Maximum Rated Input Voltages ²				
No Measurement Category	2000 Veff 6000 V transient overvoltage	1000 Veff. 1000 V transient overvoltage	400 Veff. 1000 V transient overvoltage	200 Veff. 1000 V transient overvoltage
CAT Rating	1000 V CAT III	300 V CAT II	150 V CAT II	150 V CAT II
Pollution Degree	2			
Maximum Differential Input Voltage (DC + AC peak)	500:1 $\pm 2000\text{ V}$ 250:1 $\pm 1000\text{ V}$ 100:1 $\pm 400\text{ V}$ 50:1 $\pm 200\text{ V}$	250:1 $\pm 1000\text{ V}$ 125:1 $\pm 500\text{ V}$ 50:1 $\pm 200\text{ V}$ 25:1 $\pm 100\text{ V}$	100:1 $\pm 400\text{ V}$ 50:1 $\pm 200\text{ V}$ 20:1 $\pm 80\text{ V}$ 10:1 $\pm 40\text{ V}$	50:1 $\pm 200\text{ V}$ 25:1 $\pm 100\text{ V}$ 10:1 $\pm 40\text{ V}$ 5:1 $\pm 20\text{ V}$
Common Mode Voltage	$\pm 2000\text{ V}$ peak (1400 V rms)	$\pm 1000\text{ V}$ peak (700 V rms)	$\pm 400\text{ V}$ peak (280 V rms)	$\pm 200\text{ V}$ peak (140 V rms)
DC Gain Accuracy	500:1, 250:1: $\pm 0.35\%$ 100:1, 50:1: $\pm 0.7\%$	250:1, 125:1: $\pm 0.35\%$ 50:1, 25:1: $\pm 0.7\%$	100:1, 50:1: $\pm 0.35\%$ 20:1, 10:1: $\pm 0.7\%$	50:1, 25:1: $\pm 0.35\%$ 10:1, 5:1: $\pm 0.7\%$
Propagation Delay ($\pm 0.5\text{ ns}$)	12 ns (2 m), 28 ns (6 m) 32.5 ns (7 m)	12 ns (2 m), 32.5 ns (7 m)	12 ns (2 m), 32.5 ns (7 m)	12 ns (2 m), 32.5 ns (7 m)
Noise (AC RMS) ³	500:1, 250:1: 75 mV 100:1, 50:1: 55 mV	250:1, 125:1: 37 mV 50:1, 25:1: 27 mV	100:1, 50:1: 14 mV 20:1, 10:1: 11 mV	50:1, 25:1: 7 mV 10:1, 5:1: 5 mV
Input Impedance ⁴				
Each Input to Ground	5 M Ω 5 pF	2.5 M Ω 5 pF	1.125 M Ω 5 pF	500 k Ω 5 pF
Differential Input Impedance	10 M Ω 2.5 pF	5 M Ω 2.5 pF	2.25 M Ω 2.5 pF	1 M Ω 2.5 pF
Common Mode Rejection Ratio (CMRR)	DC: 80 dB 100 kHz: 70 dB 1 MHz: 70 dB 3.2 MHz: 62 dB 10 MHz: 50 dB 50 MHz: 45 dB 100 MHz: 40 dB 400 MHz: 35 dB	DC: 80 dB 100 kHz: 70 dB 1 MHz: 70 dB 3.2 MHz: 62 dB 10 MHz: 50 dB 50 MHz: 45 dB 100 MHz: 40 dB 400 MHz: 35 dB	DC: 80 dB 100 kHz: 70 dB 1 MHz: 70 dB 3.2 MHz: 62 dB 10 MHz: 50 dB 50 MHz: 45 dB 100 MHz: 40 dB 400 MHz: 35 dB	DC: 80 dB 100 kHz: 70 dB 1 MHz: 70 dB 3.2 MHz: 62 dB 10 MHz: 50 dB 50 MHz: 45 dB 100 MHz: 40 dB 400 MHz: 35 dB

¹ Determined when using a PS-02 power supply at +23 °C ambient temperature.

² As defined within IEC 61010-031. See definitions explained in the manual.

³ Related to the input. Wideband noise DC - 30 MHz.

⁴ Including input leads. Measuring frequency 1 MHz, cable leads in parallel.

Electrical Specifications ¹

Input Coupling of the Measuring Instrument	50 Ω			
Offset ²				
Offset Correction	± 4 V			
Offset Resolution	min. 13 bit / V (min. 1 mV)			
Offset Drift	150 μ V / $^{\circ}$ C	150 μ V / $^{\circ}$ C	40 μ V / $^{\circ}$ C	40 μ V / $^{\circ}$ C

¹ Determined when using a PS-02 power supply at +23 $^{\circ}$ C ambient temperature.

² Referred to the output.

Mechanical Specifications

Weight (probe only)	370 g
Cable Length	2 m / 6 m / 7 m (model dependent)
Input Lead Length	25 cm
Input Lead Connectors	2 mm x 4 mm (male)
Output Connector	BNC (male)

Environmental Specifications

Altitude	operating	up to 2000 m
	non-operating	up to 15000 m
Temperature Range	operating	0 $^{\circ}$ C to +50 $^{\circ}$ C
	non-operating	-40 $^{\circ}$ C to +71 $^{\circ}$ C
Maximum Relative Humidity	operating	80% relative humidity for temperatures up to +31 $^{\circ}$ C, decreasing linearly to 40% at +50 $^{\circ}$ C
	non-operating	95% relative humidity for temperatures up to +40 $^{\circ}$ C

Typical Voltage Derating

Note that the max. input voltage rating of the probe decreases as the frequency of the applied sine signal increases.

Typical Voltage Derating BumbleBee® Series
No Measurement Category

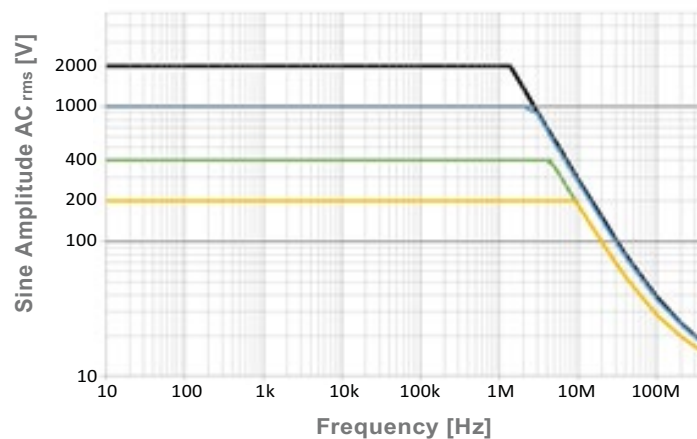
**Typical Input Impedance**

Note that the input impedance of the probe decreases as the frequency of the applied signal increases.

Typical Differential Input Impedance
BumbleBee® Series

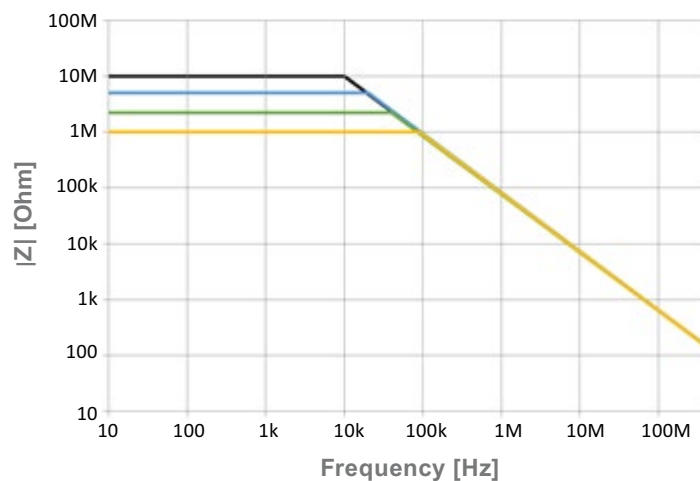

Maximum Input Voltage, Example 2000V Model, 500:1 Range

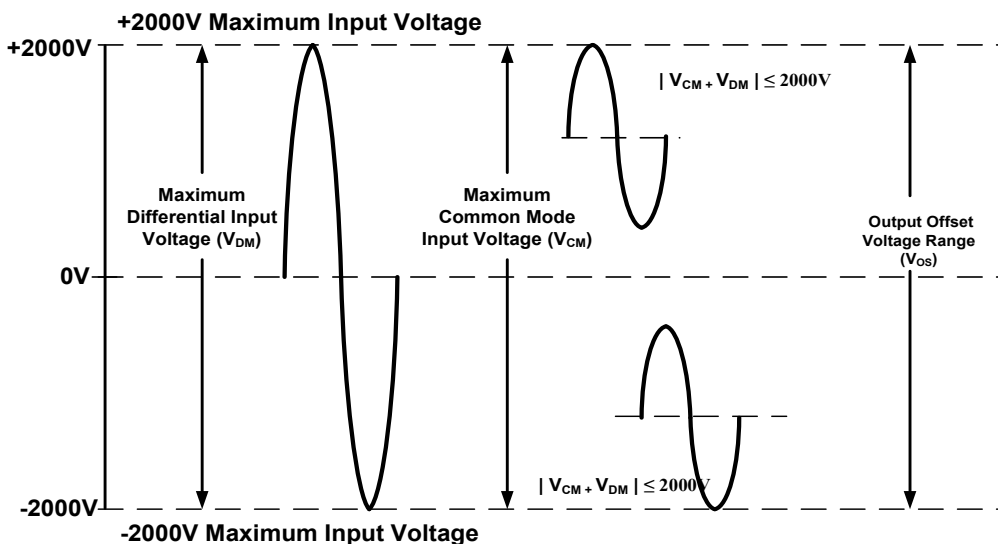

Maximum Input Voltage, Example 200V Model, 5:1 Range

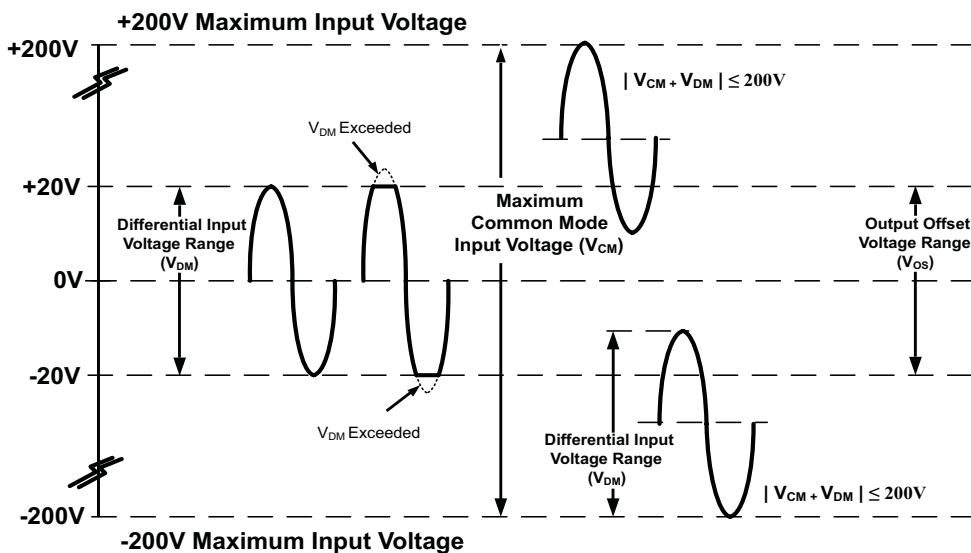

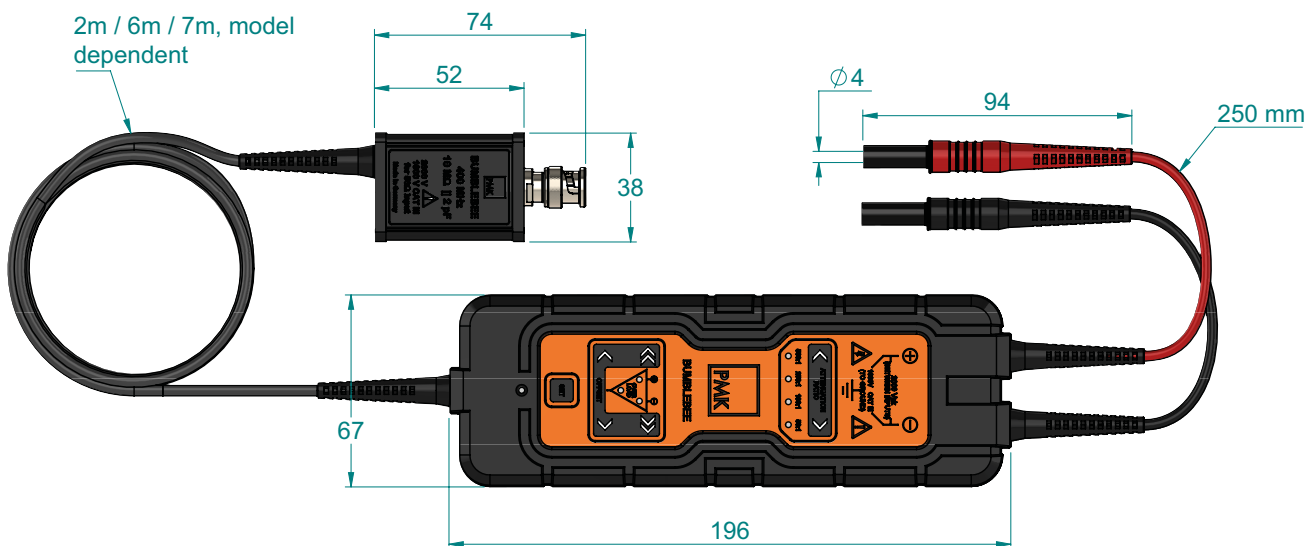

Dimensions (all models)



Probe Accessories

The parts supplied are „highlighted“ in bold in the graphical overview below, see also „Scope of Delivery“. A power supply with remote control capabilities or a battery pack for portable use is required and optional.

<p>890-880-101* Set of 10 Contact Pins 0.64 mm</p> 	<p>890-808-105 2-Footer (black)</p> 	
<p>890-880-102* Set of 4 Spring Tips (fine)</p> 	<p>890-880-103* Pair of Probe Tip Adapters 4 mm to 0.8 mm (black)</p> 	<p>890-880-104 Twinholder M6</p> 
<p>890-880-106* Pair of Mini Spring Tip Probes 4 mm (black, red)</p> 	<p>890-880-109* Pair of Magnet Connectors 4 mm (black, red)</p> 	<p>890-880-113* Pair of Clamps, Rotating Grip Jaw (black, red)</p> 
<p>890-880-107* Pair of Spade Terminals, wide (black, red)</p> 	<p>890-880-110* Pair of Spade Terminals, narrow (black, red)</p> 	<p>890-880-114* Pair of Clamps, Jaws (black, red)</p> 
<p>890-880-108* Pair of Safety Alligatorclips, big (black, red)</p> 	<p>890-880-111* Pair of Safety Alligatorclips, small (black, red)</p> 	<p>890-880-115* Pair of Clamps, Hook (black, red)</p> 
<p>890-880-112* Pair of Rail Clip Connectors 4 mm (black, red)</p> 	<p>D010031** 50Ω BNC Feedthrough, 0.5W</p> 	<p>890-880-116* 4 mm Coupler f-f (red)</p>  <p>Power Supplies</p> <ul style="list-style-type: none"> - PS-02 (2 Channel with USB) 889-09V-PS2 - PS-02-L (2 Channel with LAN and USB) 889-09V-PS2-L - PS-03 (4 Channel with USB) 889-09V-PS3 - PS-03-L (4 Channel with LAN and USB) 889-09V-PS3-L - AP-01 (Battery Pack, 1 Channel) 889-09V-AP01  <p>890-520-900 / 890-520-915* Power Supply Cable (0.5 m / 1.5 m)</p> 
		<p>016-397-055 Carrying Case "Heavy Duty" with Foam Inlays (black)</p> 

* See ratings for these accessories on next page.

** For use if only 1MΩ oscilloscope is available.

The accessories provided with the probe have been safety tested. Use original accessories only.



Rating Accessories

Part No.	Model	Rated Input Voltage
890-880-115	Clamp, hook	1000 V CAT II
890-880-114	Clamp, jaws	1000 V CAT III
890-880-113	Clamp, rotating grip jaw	1000 V CAT II
890-880-101	Contact pin 0.64mm	Not applicable
890-880-116	4mm coupler f-f	30 V AC / 60 V DC
890-880-109	Magnet connector	30 V AC / 60 V DC
890-880-106	Mini spring tip probes 4mm	600 V CAT II
890-520-900 / 890-520-915	Power supply cable	30 V AC / 60 V DC
890-880-103	Probe tip adapter 4mm to 0.8mm	1000 V CAT II
889-09V-PS2 / 889-09V-PS3	Power supply	100 - 240 V AC / 50 - 60 Hz
890-880-112	Rail clip connector	600 V CAT III
890-880-108	Safety alligator clip, big	1000 V CAT III
890-880-111	Safety alligator clip, small	600 V CAT II
890-880-107	Spade terminal, wide	30 V AC / 60 V DC
890-880-110	Spade terminal, narrow	30 V AC / 60 V DC
890-880-102	Spring tip (fine)	Not applicable

Scope of Delivery

Accessories delivered with each probe model are also highlighted in the graphical overview.



The accessories provided with the probe have been safety tested. Do not use any other accessories than those “originally” provided.

Order No.	Item	Qty
variable	BumbleBee® series probe	1
---	Factory calibration certificate	1
M80-BUMBLBEE-501	Manual	1
890-880-105	2-footer	2
890-880-102	Set of 4 spring tips (fine)	1
016-397-049	Carrying case with foam inlay (black)	1
890-880-116	4mm coupler f-f (red)	1
890-880-109	Pair of magnet connectors 4mm (black, red)	1
890-880-115	Pair of clamps, hook (black & red)	1
890-880-114	Pair of clamps, jaws (black & red)	1
890-880-113	Pair of clamps, rotating grip jaw (black & red)	1
890-880-103	Pair of probe tip adaptors 4mm to 0.8mm (2x black)	1
890-880-108	Pair of safety alligator clips, big (black & red)	1
890-880-111	Pair of safety alligator clips, small (black & red)	1
890-880-110	Pair of spade terminals, narrow (black & red)	1
890-880-107	Pair of spade terminals, wide (black, red)	1
890-880-106	Pair of mini spring tip probes 4mm (black, red)	1
890-880-101	Set of 10 contact pins 0.64mm	1
890-520-900	Power supply chable (0.5m)*	1

Ordering Information

The power supply must be ordered separately.

Models	
Order No.	Item
880-102-501	BumbleBee® ±2000V, 2m (without power supply)
880-102-504	4x BumbleBee® ±2000V, 2m inclusive 4ch power supply with USB and LAN interface PS03-L
880-106-501	BumbleBee® ±2000V, 6m (without power supply)
880-107-501	BumbleBee® ±2000V, 7m (without power supply)
880-112-501	BumbleBee® ±200V, 2m (without power supply)
880-117-501	BumbleBee® ±200V, 7m (without power supply)
880-122-501	BumbleBee® ±400V, 2m (without power supply)
880-127-501	BumbleBee® ±400V, 7m (without power supply)
880-132-501	BumbleBee® ±1000V, 2m (without power supply)
880-137-501	BumbleBee® ±1000V, 7m (without power supply)

Optional Accessories and Calibration

Order No.	Item
KAL-DAKKS-BBx	Accredited calibration according to ISO17025
016-397-055	Carrying case "Heavy Duty" with foam inlays (black)
890-880-106	Pair of mini spring tip probes 4mm
890-880-109	Magnet adaptors
890-880-112	Pair of rail clip connectors 4mm (black, red)
890-880-107	Wide spare terminals
890-880-104	Twinholder M6 for PMK positioning systems
KAL-BBx	Factory re-calibration with adjustment
D010031	50Ω BNC feed through, 0.5W

Power Supplies

Order No.	Item
889-09V-PS2	PS-02 (2 channels, with USB interface for remote control)
889-09V-PS2-L	PS-02-L (2 channels, with LAN and USB interface for remote control)
889-09V-PS3	PS-03 (4 channels, with USB interface for remote control)
889-09V-PS3-L	PS-03-L (4 channels, with LAN and USB interface for remote control)
889-09V-AP01	AP-01 (battery pack, 1 channel, no remote control)
890-520-900	Power supply cable (0.5m)*
890-520-915	Power supply cable (1.5hm)

* The power supply cable (0.5m) is included as standard with all PMK probes requiring a PS02/03/AP01 power supply.

Manufacturer

PMK Mess- und Kommunikationstechnik GmbH
Koenigsteinerstrasse 98
65812 Bad Soden am Taunus, Germany

Phone: +49 (0) 6196 5927 - 930
Fax: +49 (0) 6196 5927 - 939

Internet: www.pmk.de
E-Mail: sales@pmk.de

Copyright © 2022 PMK - All rights reserved.

Information in this publication supersedes that in all previously published material.
Specifications are subject to change without notice.